

DE1.3 Electronics 1

Lab 3 – Operational Amplifiers

Peter Cheung, 28 May 2020

**Introduction**

In this laboratory experiment, you will learn about amplification of electrical signals using a special type of chips known as an Operational Amplifier, or op-amp for short. op-amps are relatively low cost components that are flexible and useful in handling analogue signals (such as a sine wave). By the end of this Lab, you should be able to:

- Explain why a x1 amplifier is useful to reduce the loading effect on a signal source.
- Implement a x2 amplifier that works with a single power supply of +5V.
- Implement a x10 amplifier that works on small signals.
- Explain why if the gain is too high, you need more than one stage of amplification.
- Build both inverting and non-inverting amplifiers.
- Build a amplifier for a microphone signal.
- Build an audio amplifier that can drive a 8 ohm speaker

**Preparation**

Before you start this Lab, you must do two things: 1) you must put away your components used in Lab 2 for later use; 2) you must connect the top right RED power rail of the breadboard to the 5V supply on the ESP32 module as seen below:

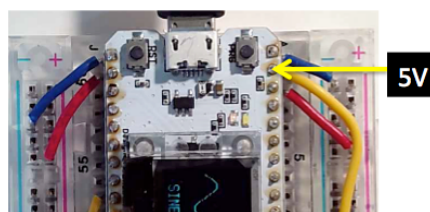
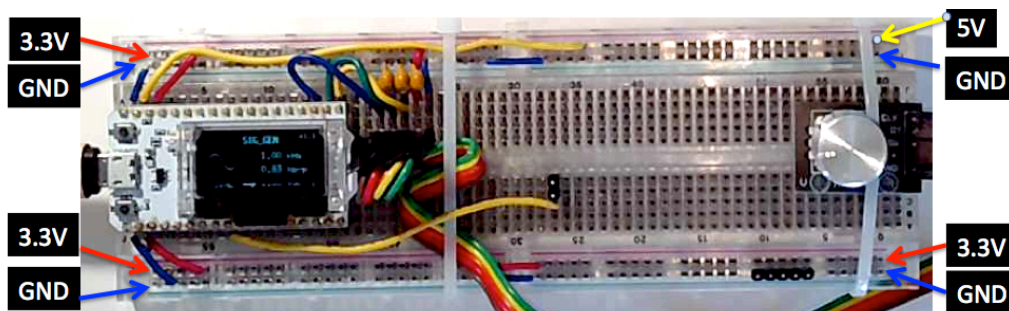

**Warning:** We use the 5V supply for analogue signals and the op-amp experiment. However, you must never connect any 5V signals to the ESP32 signal pins. The ESP32 can only accept 3.3V. The 5V supply pin on the module is connected directly to the USB socket through a 500mA fuse. If you accidentally connect other ESP32 pins to 5V, the module may be damaged beyond repair.

## Important Tips

Building complex circuits on the breadboard is not easy and is very prone to errors. You will save a lot of time by following the tips below:

- 1) Loosen the contact on breadboard – you are the first person to use this breadboard. The contacts can be difficult to receive the hookup wire. Use a male end a ribbon cable to loose the contact will make your job much easier.
- 2) Use a pair of pliers for insertion – If you have a pair of long nose pliers, grip the end of a component or a wire, and insert it into the contact hole vertically.
- 3) Draw the layout of circuit before build – It is really difficult to spot mistakes after you have inserted the components into the breadboard. It is far easier if you first plan where the components go on a piece of paper, draw in the connection wires, and check this against the schematic (circuit) diagram provide here. To check the correctness of your layout, you should tick off each connection one by one after you are sure that the connection is correct.

### Task 1: Loading effect on analque output of SIG\_GEN (Pin 26)

Set the SIG\_GEN output to sine wave signal, 10kHz, 1.65Vpk-pk and 2.5V dc offset. Measure this using the scope to make sure that this is roughly correct. Now that you have learned how to use a scope properly, you are now allowed to take a shortcut.

If you **press and hold the OK button** the scope for 3 seconds or more, you will switch on the automatic measurement mode. You can now see many signal parameters measured and reported by the scope.

Now connect a 200 $\Omega$  resistor between the Vs output (pin 26 on the ESP32 module) and GND. Measure Vpk-pk again.

Explain the reason why the peak-to-peak value of Vs is reduced when you load SIG\_GEN output with the 200 $\Omega$  resistor.

## Task 2 – Unity Gain Amplifier

For task 2, you will need: a MCP6002 dual operational amplifiers chip, a 0.1 $\mu$ F capacitor a 200 $\Omega$  and three 200k $\Omega$  resistors.

To mitigate the observed loading effect on the SIG\_GEN output, you will now build a unity gain amplifier to isolate the signal source from the output load.

### Step 1: Install the chip and 0.1 $\mu$ F decoupling capacitor

Plug into the breadboard the MCP6002 chip and connect the  $V_{DD}$  (pin 8) and  $V_{SS}$  (pin 4) of the chip to 5V and GND respectively. Note that the chip has a notch and a small indentation on the packaging. The pin closest to the indentation is Pin 1.

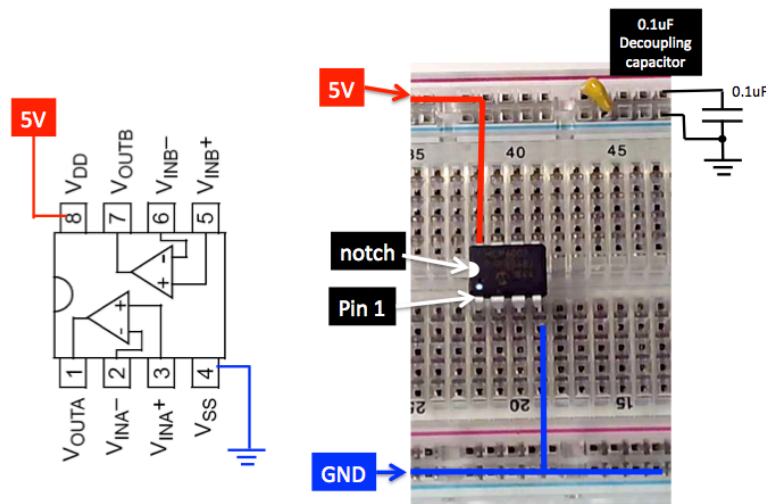

Insert a 0.1 $\mu$ F capacitor across the 5V and the GND rail as shown. This is called a “**decoupling capacitor**”. It’s function is to provide a very low impedance path for high frequency signals that somehow got onto the 5V power supply rail.

**YOU MUST ALWAYS DECOUPLE THE POWER SUPPLY IN ANY ELECTRONIC SYSTEMS. IF YOU DO NOT, THE CIRCUIT MAY GO INTO OSCILLATION.**

### Step 2: Build a unity gain non-inverting buffer

Construct the following circuit on the breadboard. You have already connected power and ground in Step 1. Here you need to add the 200k $\Omega$  resistors and connect the signal from SIG\_GEN to  $V_{INA+}$  (pin 3).

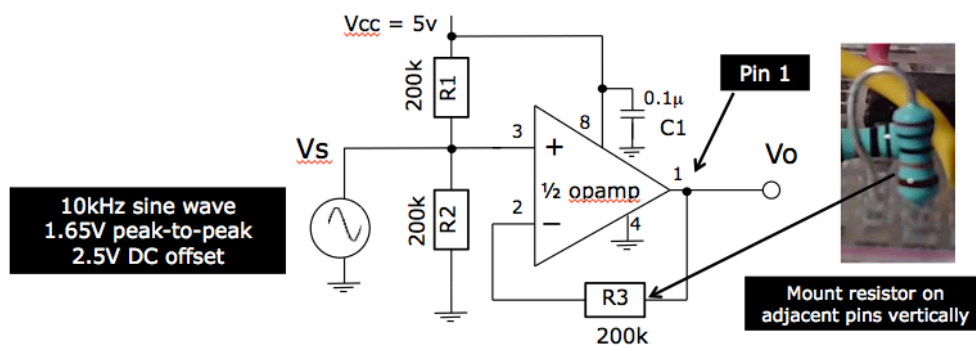

Now attached the 200 $\Omega$  resistor to  $V_o$  and observe that the peak-to-peak amplitude is no longer reduced by the load resistor. Discuss with your teammate and explain why.

### Task 3: Amplification X2 Failure

For this task, you need to use another 200kΩ resistor. Remove the 200Ω resistor at Vo. Add the resistor R4 to the circuit as shown below (shown in RED). Referring to your lecture notes and show that the expected gain of this circuit is x2.

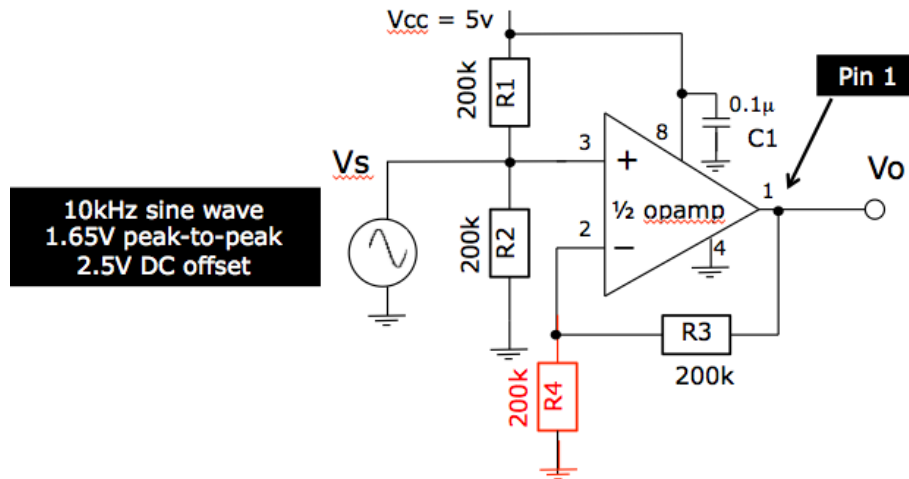

With the applied sine wave signal, measure the output Vo with the scope. What is the maximum and minimum voltage measured at Vo? You will see that the nice sine wave signal is now clipped (saturated) at the top. Discuss among your team and suggest possible explanations.

#### Task 4: AC couple of source signal and X2 amplification success

For this task, you need two additional 1 $\mu$ F capacitors. Modify your previous circuit by adding the two 1 $\mu$ F capacitors as shown below.

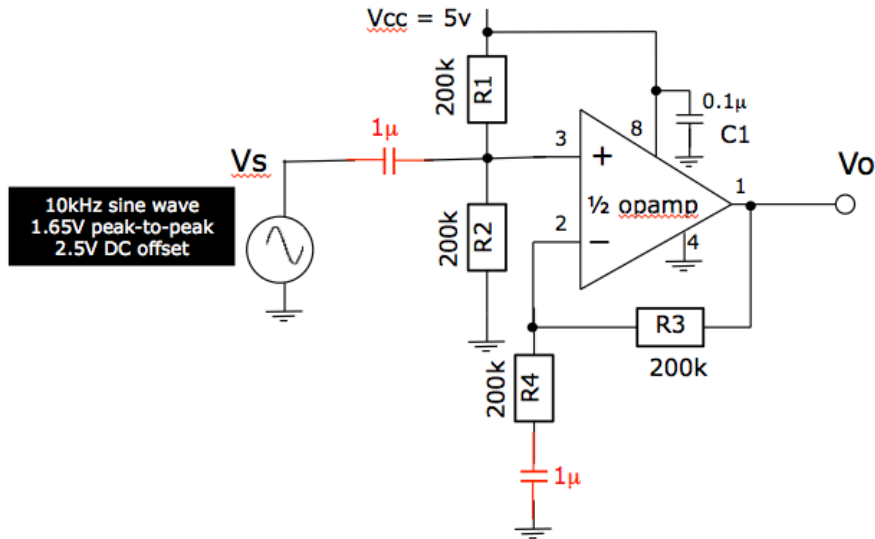

You should now see that the 1.65Vpk-pk sinewave is successfully amplified by a factor of 2 (gain is x2) and the dc offset at  $V_o$  remains to be 2.5V. This circuit is a x2 non-inverting amplifier. Why is this called “non-inverting”?

Discuss possible explanations for this results among your teammates. Record your opinion.

## Task 5: Gain-Bandwidth product limitation – large amplification fail

In this task, you will need one each 1k, 2k, 100k resistors to add to your circuit. Modify your circuit according to the diagram below.

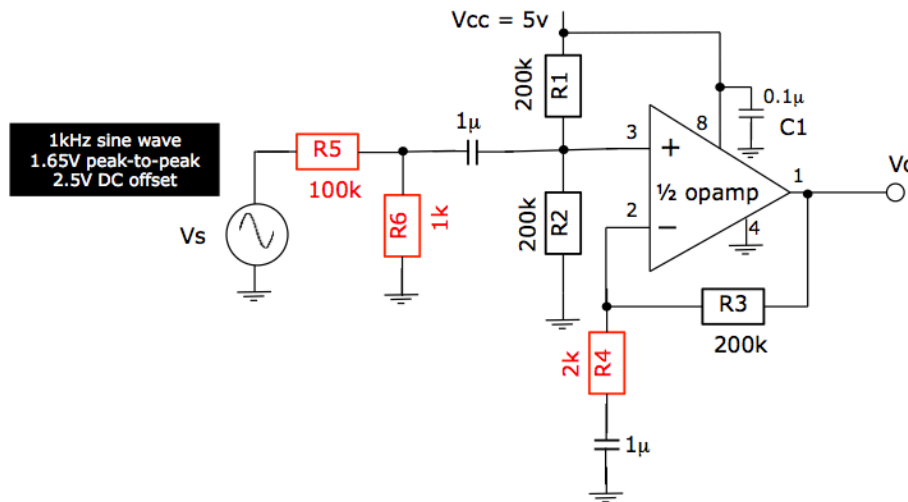

**Step 1:** Construct a voltage divider circuit with R5 and R6. Change SIG\_GEN to produce a sine wave signal at 1kHz, 1.65Vpk-pk and 2.5Vdc offset. What do you expect to see at the **input** of the op-amp (i.e. pin 3)? Discuss within your Team.

**Step 2:** Replace the 200k resistor with a 2k resistor. What is the expected gain of your amplifier now? Given the answer you provided in Step 1, what do you expect to see at the output of the op-amp Vo? Confirm with the scope that Vo is around 1.65Vpk-pk. The R5-R6 voltage divider attenuates the signal by a factor of 1/101, and the amplifier then amplify this by a factor of 101. As a result, the overall gain is 1.

**Step 3:** Now increase the frequency from 1kHz to 100kHz. What happens to Vo?

You will find that while theory suggested that you should measure around 1.65Vpk-pk at pin 1, the actual value is much small. This is because all op-amps has a limit on the product of gain x signal frequency. This is call the **Gain-Bandwidth Product (GBP)**. For our op-amp, the GBP is 1MHz. Therefore this op-amp can only provide a gain of x100 up to around 10kHz signal. Any signal beyond 10kHz the gain this op-amp can sustain will decrease accordingly.

The frequency response of our op-amp is shown below (fig 2-11 of datasheet). Ignore the phase response.

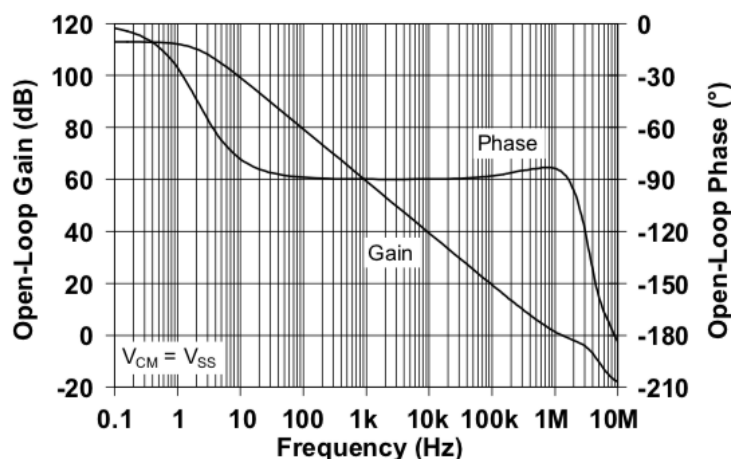

## Task 6: Inverting amplifier

For this task, you would need two 10k and one 200k and two 20k resistors in addition to those you used in the previous task.

Swap the 2k resistor of R4 with a 20k resistor in the circuit for Task 5. Show that the gain is now x11 instead of x101.

Add an additional amplifier as shown in RED below. The additional circuit is an inverting amplifier. Show that the gain for this amplifier is x10.

Build the circuit using the 2<sup>nd</sup> op-amp inside the same chip. Note that the MCP6002 chip has TWO op-amp inside. You used the first one (shaded in grey) for all the previous tasks. Now you are going to use the second op-amp (shaded in RED) to build the circuit in RED. Both op-amps share the same 5V and GND pins.

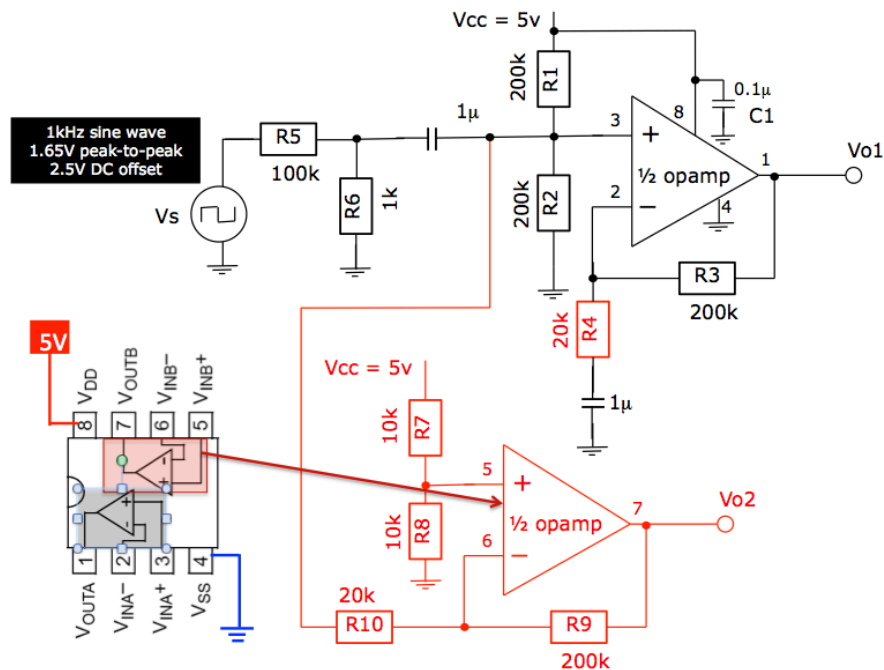

Measure Vo1 and Vo2 separately to confirm the gains of both amplifiers. Since the inverting amplifier has negative gain, Vo1 and Vo2 should have opposite phase. That means when Vo1 goes up, Vo2 should go down. However your scope only has 1 channel. Therefore this cannot be verified.

To check that the inverting amplifier DOES invert, change the signal source to a PWM signal at 1kHz and duty cycle to be, say 25%. Now compare Vo1 and Vo2.

## Task 7: Amplify a microphone signal

**Step 1:** The two amplifiers are driven by the same input signal. They are connected in parallel. Now connect them in series by connecting the input of the 2<sup>nd</sup> amplifier (the inverting one) to Vo1. The overall output for both stages of this two-stage amplifier is now Vo2.

Show that the gain should be approximately 110.

**Step 2:** Replace the SIG\_GEN signal source with the microphone supplied. Connect this to the 5V power via R11 (10k resistor).

Download a free tuning fork app onto your phone and use that to generate a sine wave signal. Measure the signal at the terminal of the microphone, and see how the two-stage amplifier manage to produce a sizable signal at the output Vo2.

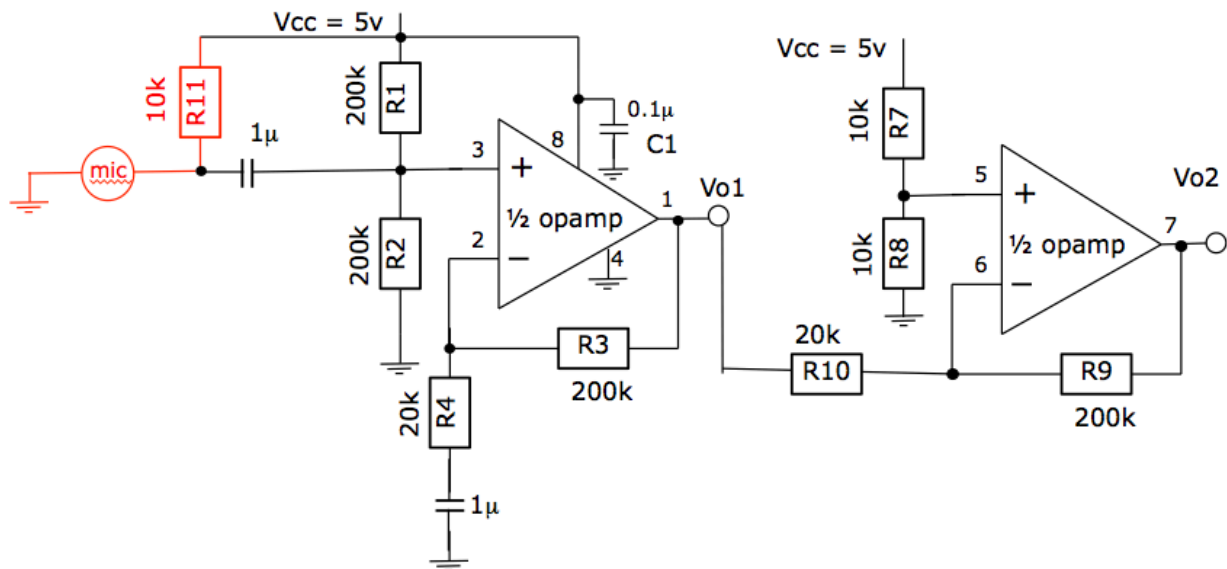



### Task 8: Audio Amplifier (optional)

You will find in your component box a small  $8\Omega$  speaker. Try connect this directly to the op-amp output  $V_{o1}$  or  $V_{o2}$ . You will not hear very much. This is because the op-amp is NOT designed to drive such a low impedance. Its maximum output current is only around 20mA. Therefore the peak output voltage with 20mA and  $8\Omega$  load resistance is only 160mV.

To drive such a speaker, you need a special type of amplifier called audio amplifier such as the one that is provided in your component box.

Build the following circuit and listen to the output sound from the speaker. The LM386 audio amplifier in this configuration has a gain of +20dB (x10) and can easily drive the  $8\Omega$  speaker.

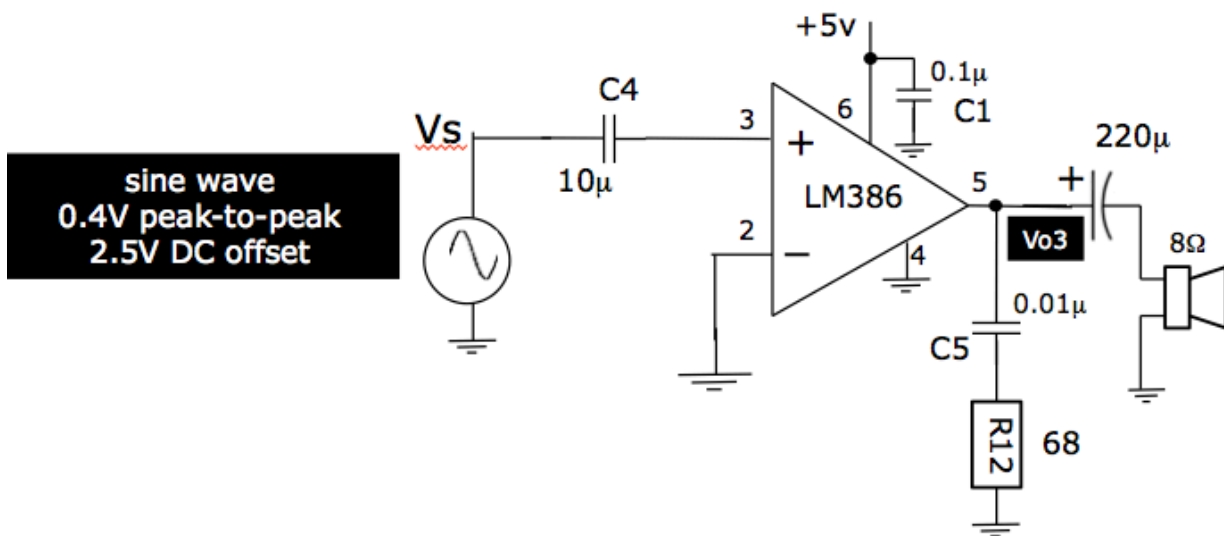

### Tidy Up

Congratulations! You have completed Lab 3. Now it is time to tidy up again and return all components to your Card Stores for future use. You will need many of these components later.